

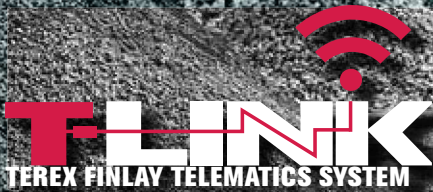

TEREX | FINLAY



693+

693+ SUPERTRAK

SPECIFICATION:

Screen Size:		6100mm x 1530mm (20' x 5')
Net Engine Power:	Tier 3 / Stage IIIA:	Caterpillar C4.4 83kW (111.3hp)
	Stage IIIA Constant Speed:	Caterpillar 4.4 98.1kW (131hp)
	Tier 4F / Stage IV:	Caterpillar C4.4 82kW (110hp)
Portability:		Tracked
Operating Weight:		34,850kg (76,831lbs)*
		<i>*With tipping grid</i>



SPECIFICATION

HOPPER AND GRID

Hopper Capacity: 8m³ (10.5yd³)

Feed height: 3.67m (12')

Feed in width: 4.77m (15' 8") (grid wing plates)

Grid aperture: 100mm (4")

10mm replaceable steel hopper liners

Drive: Hydraulic variable speed drive via high torque gearbox

Beltfeeder belt width: 1.2m (48")

Belt Spec: Plain EP 630, 4 ply, 6 + 2mm covers

Speed: variable, 0 - 16 mpm (0 - 53' per min)

Wide mouth opening

MAIN CONVEYOR

Drive: Hydraulic drive via high torque 630cc motor

Belt width: 1.2m (48")

Belt spec: Plain 3 ply belt, EP400

Hydraulic adjust

Belt Speed: 92 mpm (302' per min)

Steel skirted full length of conveyor

SCREEN BOX

All decks: 6.1m x 1.53m (20' x 5')

Wedge side tensioned top deck mesh

Hydraulic end tensioned bottom deck mesh

Drive: Hydraulic heavy duty 2-Bearing

Screen Angle: 18° - 30°, hydraulic adjust

Screen Speed: 1000 rpm

Screen stroke standard: 6mm (1/4")

Abrasion resistant material impact plate

Spreader plate

Galvanised access catwalks on both sides and top end of screen

Total screening area: 18.5m² (200ft²)

SIDE CONVEYORS

Drive: Hydraulic variable speed drive via high torque 500cc motor

Belt width: 800mm (32")

Belt spec: Chevron EP400, 3 ply

Working Angle: 24°

Speed: Variable speed, 0 - 125mpm (0 - 410' per min)

Hydraulic Folding

Discharge Height: 4.71m (15' 5")

Stockpile capacity: 145m³ (190yd³)



Hopper and Grid



Screenbox with all round catwalk access



Main Conveyor



Fines Conveyor



Side Conveyor

FINES CONVEYOR

Drive: Hydraulic variable speed drive via high torque 800cc motor

Belt width: 1.2m (48")

Belt spec: Plain, 3 ply, EP400

Working Angle: Variable 25° (Max)

Rosta scraper on head drum

Speed: 92 mpm (302' per min)

Standard Discharge Height: 4.86m (15' 95")

Stockpile capacity: 159m³ (208yd³)

POWERUNIT AND HYDRAULICS

Tier 3 / Stage IIIA: Caterpillar 4.4

Engine Power: 83kW (111.3hp)

Engine Speed: 2200 rpm

Stage IIIA Constant Speed: Caterpillar C4.4

Engine Power: 98.1kW (131hp)

Engine Speed: 1800 rpm

Tier 4F / Stage IV: Caterpillar 4.4

Engine Power: 82kW (110hp)

Engine Speed: 2200 rpm

Pump 1: Triple 33cc/33cc/26cc (Tier 3 & Tier 4)

The first section drives either the (right) track or split to drive the middle grade & "oversize minus" conveyor

The second section drives either the (left) track or the main conveyor

The third section drives belt feeder

Pump 2: Tandem 46cc/27cc (Tier 3 & Tier 4)

The first section drives the fines conveyor and screen

The second section operates the vibrating or tipping grid

Pump 1 Triple 61cc/rev, 41cc/rev, 41cc/rev (Constant Speed)

The first section drives the fines conveyor and screen

The Second section drives either the (left) track or the belt feeder

The third section drives either the (right) track or operates the vibrating or tipping grid

Pump 2 Tandem 33cc/33cc (Constant Speed)

The first section drives the the main conveyor

The second section operates the middle grade & "oversize minus" conveyor

TANK CAPACITIES

Hydraulic Tank: 450 litres / 99 UK gal / 119 US gal

Fuel Tank: 336 litres / 74 UK gal / 88 US gal

UNDERCARRIAGE

Shoe Width: 500mm (20")

Sprocket Centres: 3.8m (12' 5")

Speed: 0.8 km/h

Gradeability: 32.6°

Raking Angle: 9°



Side Conveyor



Powerunit



Pump 1: Triple 33cc/rev, 33cc/rev, 26cc/rev



User Friendly Interface

STANDARD FEATURES

ENGINE:

Tier 3 / Stage 3A Caterpillar C4.4 - 4 cylinder diesel engine developing 83kW (111.3 hp) 2200 RPM

Stage IIIA CAT 4.4 constant speed engine - 4 cylinder diesel engine developing 98.1kW (131hp) @1800rpm - Europe Only

FEEDER:

Hopper Capacity: 8m³ (10.5yd³)

Hopper feed length: 4.25m (14ft)

Belt width: 1.05m (42") variable speed belt feeder

Remote control hydraulic tipping reject grid c/w grouser bars 4.25m x 100mm spacing (14' 0" x 4")

SCREENBOX:

6.1m x 1.53m (20' x 5') top and bottom deck screenbox

No mesh or speedharps included for any deck (but all mesh fitting parts included as standard)

Quick wedge tensioning - top deck

Hydraulic tensioning (bottom deck screen mesh)

MAIN CONVEYOR:

Belt Width: 1.2m (48") c/w skirting

SIDE CONVEYORS:

Belt Width: 800mm (32") chevron on both side conveyors

FINES CONVEYOR:

Belt Width: 1.2m (48")

ELECTRICAL:

Emergency Stops

Control operation of tracks via hand-held set

T-Link Telemetry System fitted c/w 3 years data (only included with CAT 97kW Engine)

GENERAL:

Safety guards in compliance with machinery directive

Low level central greasing

OPTIONAL EQUIPMENT

Tier 3 / Stage 3A Caterpillar C4.4 - 4 cylinder diesel engine developing 97kW (130hp) @ 2200rpm

Dual Power - 2 x 37kW IE3 electric motors c/w hydraulic gear pumps and electrical control panel allowing machine to run in either Diesel or Electric mode**

**STD voltage supply: 380V - 440v @ 50Hz. (Contact the factory for availability, leadtime and if any local requirements are different from standard offering")

Tier 4F / Stage IV - Caterpillar C4.4 - 4 cylinder diesel engine developing 82kW (110hp) @ 2200 RPM

No grid but hopper deadplate fitted

100mm Double deck vibrating grid c/w abrasion resistant plate on wear surface of T Bars top dk and mesh in bottom deck (includes Hopper inlet chute from crusher)

Remote control hydraulic tipping reject grid c/w grouser bars 3.65m x 100mm spacing (12' 0" x 4") and hopper inlet chute from crusher

Top deck mesh

Bottom deck mesh/ speedharp

Screenbox Rotation Reversal control

Anti Roll back plates for main conveyor (3Nr)

Hydraulic raise of Main Conveyor head-section (For improved mesh access)

Aluminium Rapid-Fit dust covers on main and fines belt

Dust suppression system on fines belt. Does not include waterpump

Radio Remote control of tracks

Working lights on powerunit & main conveyor

68 grade hydraulic oil

1nr Standard stockpiler drive - Approx 30 Litres/min (only available when no vibrating grid fitted)

OR Quad Pump option for 1nr dedicated Stockpiler Drive - Approx 70 Litres/min (Not available on Constant Speed Engine or Dual Power Setup)

Special paint colour (if different from Finlay Orange RAL 2002). RAL must be specified on order

Main conveyor

- ▶ Drive: Hydraulic drive via torque 630cc motor
- ▶ Belt width: 1.2m (48")
- ▶ Belt spec: Plain 3 ply belt, EP400
- ▶ Hydraulic adjust
- ▶ Belt Speed: 92mpm (302' per min)
- ▶ Steel skirted full length of conveyor

Screen box

- ▶ All decks: 6.1m x 1.53m (20' x 5')
- ▶ Wedge side tensioned Top and Middle Deck mesh
- ▶ Hydraulic end tensioned bottom deck mesh
- ▶ Drive: Hydraulic heavy duty 2-Bearing
- ▶ Screen Angle: 18° - 30°, hydraulic adjust
- ▶ Screen Speed: 1000 rpm
- ▶ Screen stroke standard: 6mm (1/4")
- ▶ Abrasion resistant material impact plate
- ▶ Spreader plate
- ▶ Galvanised access catwalks on both sides and top end of screen
- ▶ Total screening area: 18.5m² (200ft²)

Fines conveyor

- ▶ Drive: Hydraulic variable speed drive via high torque 800cc motor
- ▶ Belt width: 1.2m (48")
- ▶ Belt spec: Plain, 3 ply, EP400
- ▶ Working Angle: Variable 25° (Max)
- ▶ Rosta scraper on head drum
- ▶ Speed: 92 mpm (302' per min)
- ▶ Standard Discharge Height: 4.86m (15' 95")
- ▶ Stockpile capacity: 159m³ (208yd³)

Hopper / Feeder

- ▶ Hopper Capacity: 8m³ (10.5yd³)
- ▶ Feed height: 3.67m (12')
- ▶ Feed in width: 4.77m (15' 8") (grid wing plates)
- ▶ Grid aperture: 100mm (4")
- ▶ 10mm replaceable steel hopper liners
- ▶ Drive: Hydraulic variable speed drive via high torque gearbox
- ▶ Beltfeeder belt width: 1.2m (48")
- ▶ Belt Spec: Plain EP 630, 4 ply, 6 + 2mm covers
- ▶ Speed: variable, 0 -16 mpm (0 - 53' per min)
- ▶ Wide mouth opening

Middle grade conveyor

Oversize Conveyor

- ▶ Drive: Hydraulic variable speed drive via high torque 500cc motor
- ▶ Belt width: 800mm (32")
- ▶ Belt spec: Chevron EP400, 3 ply
- ▶ Working Angle: 24°
- ▶ Speed: Variable speed, 0-125mpm (410' per min)
- ▶ Hydraulic Folding
- ▶ Discharge Height: 4.71m (15' 5")

Power unit

- ▶ Tier 3 / Stage IIIA: Caterpillar C4.4
Engine Power: 83kW (111.3hp)
Engine Speed: 2200 rpm
- ▶ Tier 3 / Stage IIIA Constant Speed: Caterpillar C4.4
Engine Power: 98.1kW (131hp)
Engine Speed: 1800 rpm
- ▶ Tier 4F / Stage IV: Caterpillar 4.4
Engine Power: 82kW (110hp)
Engine Speed: 2200 rpm

Undercarriage

- ▶ Shoe Width: 500mm (20")
- ▶ Sprocket Centres: 3.8m (12' 5")
- ▶ Speed: 0.8 km/h
- ▶ Gradeability: 32.6°
- ▶ Raking Angle: 9°

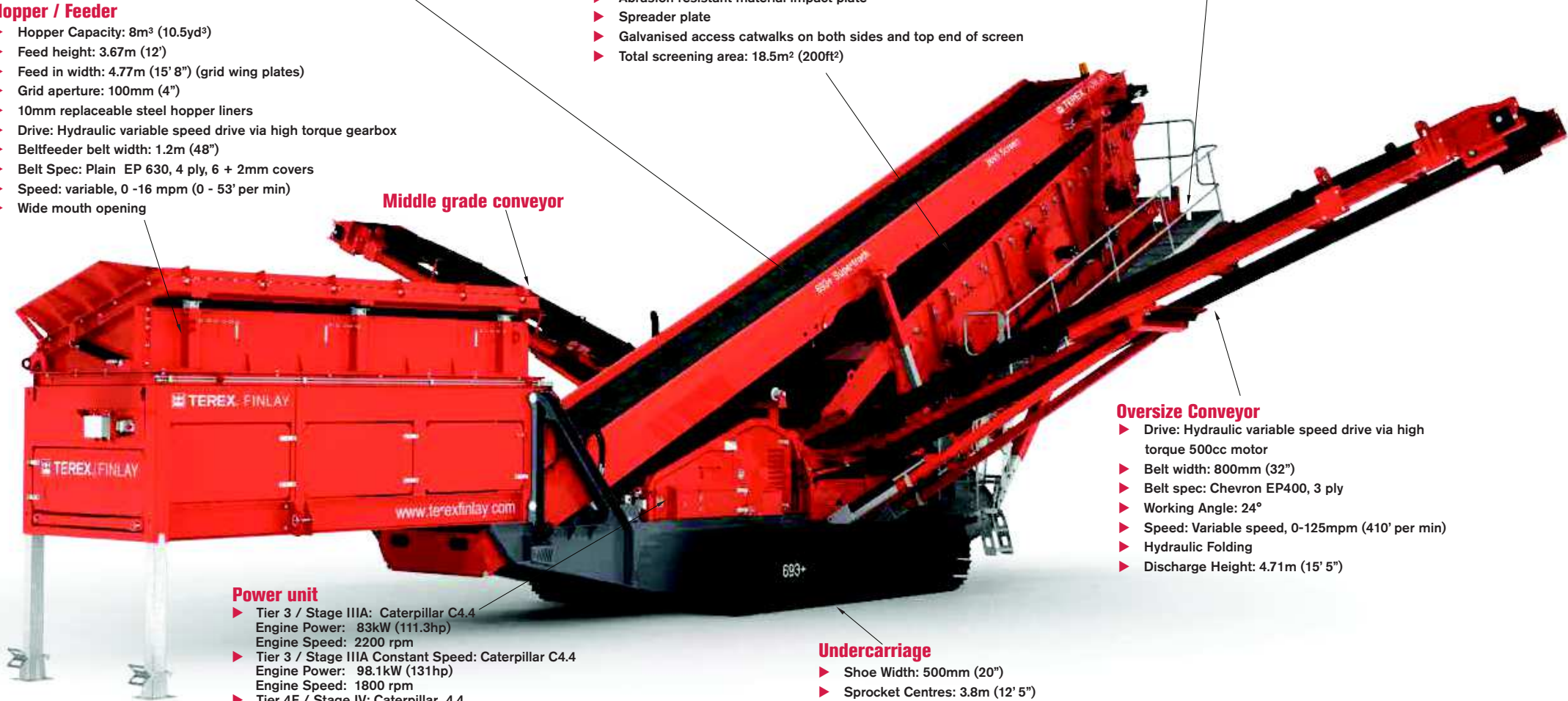

693+

TRANSPORT DIMENSIONS



WORKING DIMENSIONS

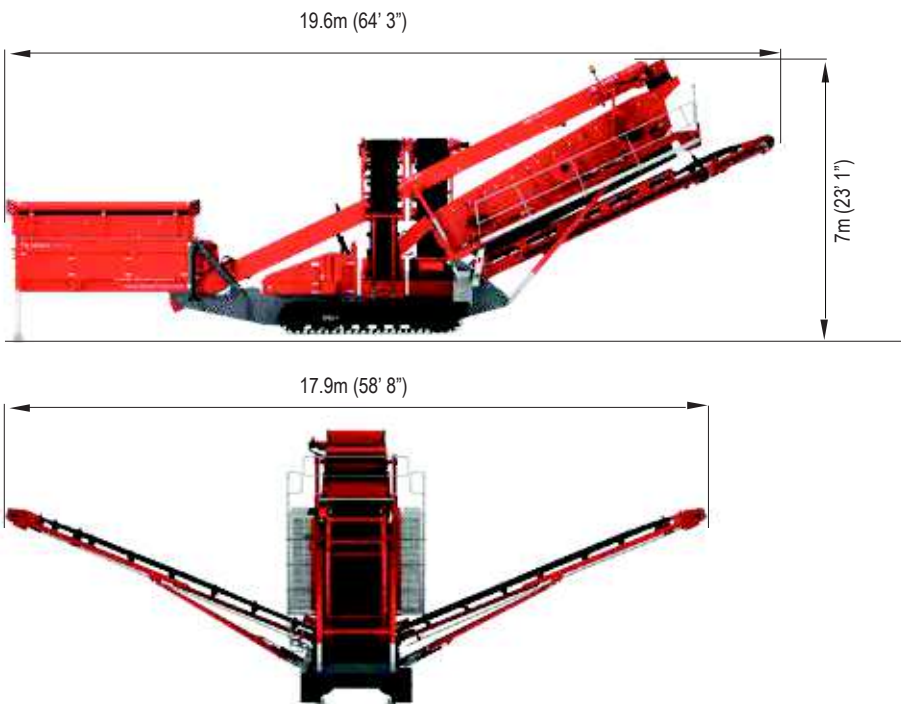

MACHINE WEIGHT: 34,850kg (76,831lbs)

with tipping grid

For further information on specific machine weight configurations please consult Terex Finlay

