

# C-1540P

## CONE CRUSHER



Cone Head Diameter: 1000mm (40")

Net Engine Power: Tier 3/Stage IIIA:

Tier 4F:

Stage V:

Portability:

Tracked

Operating Weight: 40,220kg 9(88,670lbs) (with optional pre-screen)

Caterpillar C9 Acert 261kW (350hp)

Scania DC09 257kW (350hp)

Scania DC09 257kW (350hp)

# SPECIFICATION

## HOPPER / FEEDER

Hopper capacity: 5m<sup>3</sup> (6.5yd<sup>3</sup>)

Feed height: 2.93m (9' 7") (Pre-screen position), 2.8m (9' 2") (Direct feed position)

Feed height with optional hopper extensions: 3.33m (10' 11") (Pre-screen position), 3.2m (10' 6") (Direct feed position)

Hopper fabricated in 10mm mild steel plate with 10mm wear resistant steel liners at impact point

Hopper Width at rear: 2.45m (8')

Hopper Width at rear with optional hopper extensions: 3.7m (12' 2")

Belt Spec: Plain

Belt Width: 1.05m (42")

Speed range: Variable, 0 – 31 m/min (0 – 101 ft/min)

Working Angle: 24° (Pre-screen feed), 21° (Direct feed)

Drive: Hydraulic variable speed drive via gearbox

Drop down rear door for auxiliary crusher feed

Crash bar fitted to reduce impact load on feed conveyor

Rubber covered impact rollers fitted

Hydraulic retraction system for ease of movement between transport and working modes

Full length skirting to head drum

Automatic variable speed conveyor ensures maximum output from plant

Metal detection system with 'auto-stop' feature is suitable for detecting steel and manganese steel contained in the feed material

Controllable discharge system to purge metal contaminants. This feature allows the operator to clear metal from the feed conveyor when it is detected. The contaminated material is dumped to the side of the machine. This can be done on the main control panel or remotely via the optional radio remote

## CONE CHAMBER

Terex 1000mm (40") cone chamber

Cone Counter Shaft Speed Range: 840 - 940 rpm

Variable speed control settings for producing a quality aggregate

Long throw fitted on standard configuration

Drive arrangement: Direct hydrostatic cone drive with electronic speed control system

'On the fly' hydraulically adjustable closed side setting with monitoring system

Mantle/concave wear indicator

Hydraulic overload protection with automatic reset. This allows the upper frame to lift up, to permit the passage of tramp iron and other un-crushable material. The system then automatically returns the upper frame to its original position



Hopper and Feeder



Hopper and Feeder



Hopper and Pre-screen



Cone Chamber

## CONE CHAMBER continued

Unrestricted feed opening reduces blockages, bridging and maximizes output

Independent cone oil lubrication tank with separate oil cooler

Level sensor fitted over inlet feed box maintains the optimum choke feed condition hence maximizing the reduction and manganese life

Dust suppression fitted at cone inlet and outlet

Concave	Maximum Feed Size	Maximum CSS	Minimum Recommended CSS
Medium Coarse	160mm (6 5/16")	36mm (1 7/16")	19mm (3/4")
Coarse	175mm (6 7/8")	36mm (1 7/16")	19mm (3/4")
Extra Coarse	195mm (7 11/16")	36mm (1 7/16")	22mm (7/8")
Sand	63mm (2 1/2")	32mm (1 1/4")	13mm (1/2")

\*Note: Minimum Recommended CSS subject to feed conditions

## MAIN CONVEYOR

Belt Width: 900mm (36")

Belt Spec: Plain

Working Angle: 21°

Speed: 98 – 105 m/min (321 – 344 ft/min)

Discharge Height: 3.3m (10' 10")

Impact bars and wear resistant liners at feed point

High spec scraper at head drum

Dust suppression: fitted with hose and spraybars as standard (no pump supplied)

Full length skirting to head drum

Dust covers

Standard Stockpile capacity: 53.5m<sup>3</sup> (70yds<sup>3</sup>) @ 40°



Main Conveyor

## POWERPACK

Tier 3 / Stage IIIA : Caterpillar C9 ACERT

Engine Power: 261kW (350hp)

Engine Speed: 1900 rpm

Tier 4F: Scania DC09

Engine Power: 257kW (350hp)

Engine Speed: 1900 rpm

Stage V: Scania DC09

Engine Power: 257kW (350hp)

Engine Speed: 1900 rpm



Scania Engine

## TANK CAPACITIES

Hydraulic Tank: 720 litres / 158 UK gal / 190 US gal

Fuel Tank: 720 litres / 158 UK gal / 190 US gal

Urea Tank: 60 litres / 13 UK gal / 15 US gal



Cat Engine

## PRE-SCREEN MODULE (OPTIONAL)

### A) Screen

Top deck: 1.83m x 1.22m (6' x 4')

Total screening area: 2.23m<sup>2</sup> (24ft<sup>2</sup>)

Tensioning top deck: side

Drive: hydraulic with heavy duty bearing

Screen Angle: 25°

Screen Speed: 1200 rpm

The pre-screen module will maximise production through the cone by removing as much fine material as possible before it enters the cone chamber. This will also reduce wear within the cone chamber

Pre-screen can be by-passed and material feed directly into cone if required

Hydraulically folds for transport

### B) Transfer Conveyor

Belt Width: 1m (40")

Belt Spec: Plain

Working Angle: 23°

Speed: 71 – 94 m/min (232 – 308ft/min)

Hydraulically folds for transport along with pre-screen

Can be raised hydraulically to aid screen mesh changing

Dust cover

Full length skirting to head drum



Pre-screen module in working mode



Pre-screen module in working mode

## PRE-SCREEN SIDE CONVEYOR (OPTIONAL)

Belt Width: 650mm (26")

Belt Spec: Plain

Working Angle: 23°

Speed: 75 - 90 m/min (246 - 295ft/min)

Conveyor has to be manually lifted off for transport & is transported with the plant

Discharge Height: 3.65m (12')

Stockpile capacity: 69.4m<sup>3</sup> (90.8yd<sup>3</sup>) @ 40°



Pre-screen side Conveyor



Pre-screen side Conveyor

## UNDERCARRIAGE

Shoe Width: 500mm (20")

Sprocket Centres: 3.80m (12' 6")

Tracking Speed: 0.8 km/h

Gradeability: 25°



Undercarriage

## TOOL BOX

Mounted lockable toolbox

Tool kit supplied

Two grease guns supplied – one for machine, one for cone



Tool Box

## CHUTES

Quick release cone feed box for cone wear part changes

Cone chamber feed box fabricated in 6mm mild steel plate

Cone chamber discharge chute fabricated in 5mm mild steel plate with 15mm wear resistant steel liners fitted at impact point

Contamination chute fabricated in 6mm mild steel plate



Chutes

## CONTROL SYSTEM

Advanced CANBUS compliant system

Large colour display screen

Main menu consists of five modes:

Automatic mode: For automatically starting the machine in a set sequence

Track mode: For moving machine

Setup mode: For folding / setting up machine

Cone setup mode: For testing / setting of cone

Configuration mode: For testing / setting individual components / monitoring engine performance and faults / monitoring machine faults

User friendly incremental selection of feeder and crusher speed, enable the operator to achieve the optimal throughput and product shape

The main control panel is mounted to the side of the machine in a lockable compartment

Detachable umbilical control for tracking



Control System

## PLATFORMS

Galvanised catwalks and ladders for full maintenance and service access

Catwalks on both sides of the machine

Compact folding for transport

## REMOTE CONTROL UNIT (OPTIONAL)

Full function radio remote unit:

- Auto start / stop
- Feed conveyor start / stop
- Metal purge sequence
- Tracking



Remote Control Unit (Optional)

## STANDARD FEATURES

### ENGINE:

Tier 3 / Stage IIIA:- Caterpillar C9 ACERT 261kW (350hp)

Tier 4 Final /: Scania DC09 257kW (350hp)

Stage V: Scania DC09 257kW (350hp)

### CONE CHAMBER:

Terex TC1000

Long throw eccentric, medium coarse concave (max feed size 160mm)

Hydrostatic cone drive

### HOPPER / FEEDER:

Fixed wear resistant hopper

Belt Width: 1050mm (42")

Metal detector & Metal contaminants purge system

### MAIN CONVEYOR:

Belt width: 900mm (36")

Dust covers

### CLIMATE SPEC:

Standard oils (Recommended for ambient temperatures between -5 to +30°C)

### DUST SUPPRESSION:

Piped for dust suppression c/w spraybars

### ELECTRICAL:

Emergency stops

Hand held track control set with connection lead

T-Link Telemetry System fitted c/w 7 years data subscription

### GENERAL:

Safety guards in compliance to machinery directive

Two auxiliary drives (NOTE - SOME OPTIONS REQUIRE AN AUXILIARY WHICH USE THESE)

## OPTIONAL EQUIPMENT

Extra coarse concave - max feed size 195mm (check lead time) <sup>1</sup> (NOTE - NOT RECOMMENDED TO BE USED WITH PRE-SCREEN SYSTEM)

Coarse concave - max feed size 175mm (check lead time) <sup>1</sup>

Sand concave - max feed size 63mm (check lead time) <sup>1</sup> (RECOMMENDED TO TAKE SHORT THROW ECCENTRIC OPTION)

Short throw eccentric (check lead time) <sup>1</sup>

Manual hopper extensions

Belt weigher

### Pre-Screen

1.83m x 1.22m (6' x 4') single deck screen. 16mm aperture mesh fitted, unless specified otherwise. Max feed size 160mm. Requires 1 auxiliary drive

Side conveyor

Hot climate lubrication kit (Recommended for ambient temperatures between +15 to +50°C)

Cold climate lubrication kit (Recommended for ambient temperatures between -20 to +30°C)

Hot climate cooler pack c/w hot climate lubrication kit (Recommended for ambient temperatures >+35°C) Requires 1 auxiliary drive

Electric driven water pump

Electric Re-fuelling pump

Radio remote system

Control panel positive air pressurization

Lighting mast

Base System, contains all hardware, 2x Cameras and tablet with attachments

Crusher expansion kit, contains all hardware and 2x cameras

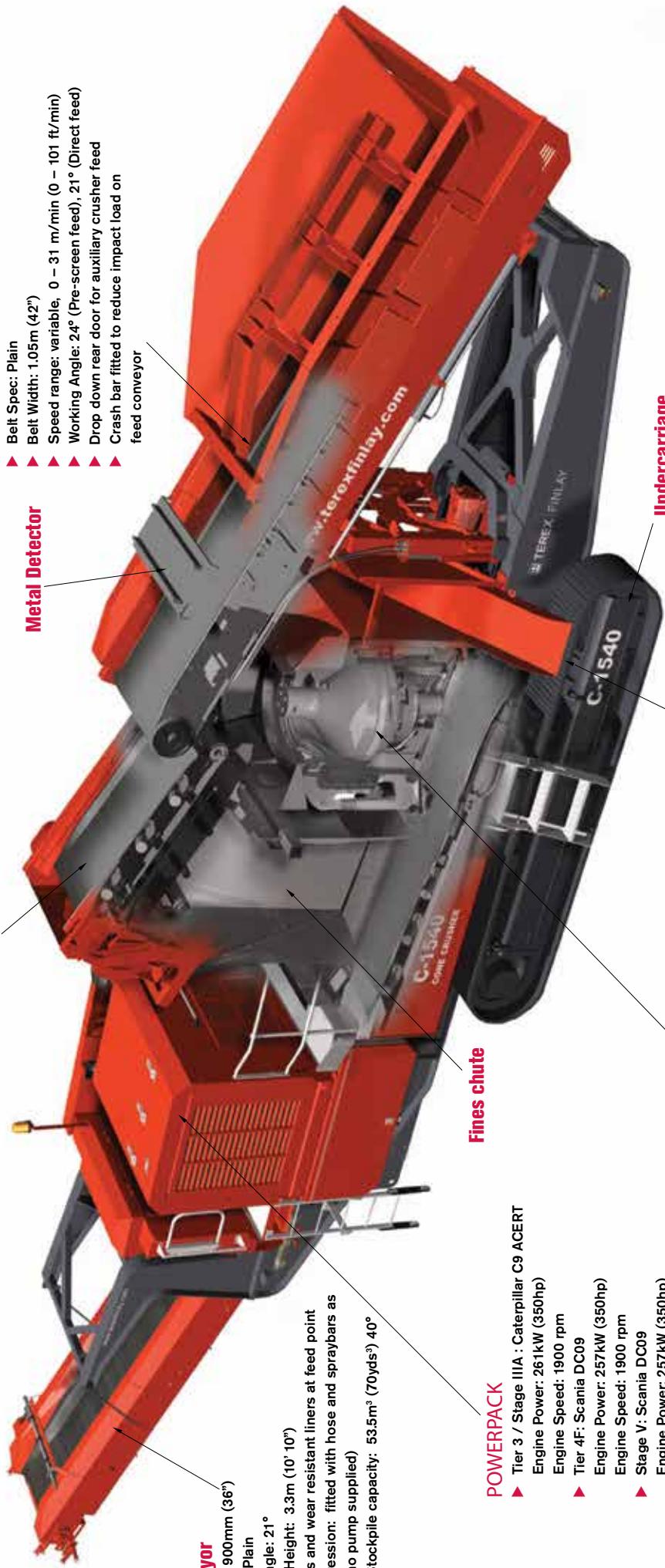

### Pre-screen system (optional)

- ▶ Top deck: 1.83m x 1.22m (6' x 4')
- ▶ Screen Angle: 25°
- ▶ Screen speed: 1200 rpm
- ▶ The pre-screen module will maximise production through the cone by removing as much fine material as possible before it enters the cone chamber. This will also reduce wear within the cone chamber

### Metal Detector

### Hopper / Feeder

- ▶ Hopper capacity: 5m<sup>3</sup> (6.5yd<sup>3</sup>)
- ▶ Hopper fabricated in 10mm mild steel plate with 10mm wear resistant steel liners at impact point
- ▶ Hopper width at rear: 2.45m (8')
- ▶ Belt Spec: Plain
- ▶ Belt Width: 1.05m (42")
- ▶ Speed range: variable, 0 – 31 m/min (0 – 101 ft/min)
- ▶ Working Angle: 24° (Pre-screen feed), 21° (Direct feed)
- ▶ Drop down rear door for auxiliary crusher feed
- ▶ Crash bar fitted to reduce impact load on feed conveyor

### Main conveyor

- ▶ Belt Width: 900mm (36")
- ▶ Belt Spec: Plain
- ▶ Working Angle: 21°
- ▶ Discharge Height: 3.3m (10' 10")
- ▶ Impact bars and wear resistant liners at feed point
- ▶ Dust suppression: fitted with hose and spraybars as standard (no pump supplied)
- ▶ Standard Stockpile capacity: 53.5m<sup>3</sup> (70yds<sup>3</sup>) 40°

### Fines chute

### POWERPACK

- ▶ Tier 3 / Stage IIIA : Caterpillar C9 ACERT
- ▶ Engine Power: 261kW (350hp)
- ▶ Engine Speed: 1900 rpm
- ▶ Tier 4F: Scania DC09
- ▶ Engine Power: 257kW (350hp)
- ▶ Engine Speed: 1900 rpm
- ▶ Stage V: Scania DC09
- ▶ Engine Power: 257kW (350hp)
- ▶ Engine Speed: 1900 rpm

### Undercarriage

- ▶ Shoe Width: 500mm (20")
- ▶ Sprocket Centres: 3.80m (12' 6")
- ▶ Tracking Speed: 0.8 km/h
- ▶ Gradeability: 25°

### Metal purge chute

### Cone chamber

- ▶ Terex 1000mm (40") cone chamber
- ▶ Cone counter shaft Speed Range: 840 - 940 rpm
- ▶ Variable speed control settings for producing a quality aggregate
- ▶ 'On the fly' hydraulically adjustable closed side setting with monitoring system

## TRANSPORT DIMENSIONS



## WORKING DIMENSIONS



**MACHINE WEIGHT:** 40,220kg (88,670lbs)  
with optional pre-screen  
42,030kg (92,660lbs)  
with optional pre-screen, pre-screen side conveyor & hopper  
extensions

For further information on specific machine weight configurations please consult Terex Finlay